

Innovative Adhesives for Medical Devices

**Adhesives with biocompatibility in compliance with
USP Class VI and/or ISO-10993 for**

**Catheters and connectors
Respiratory equipment
Needle bonding
Wearables
Diagnostics
Sensors**

Panacol offers a broad spectrum of cutting-edge adhesives. We provide complete processing solutions for the medical industry that include adhesives and coatings as well as UV- and LED-UV curing equipment. These solutions contain adhesives for needle bonding and assembly of plastic housings. Adhesives are also available for PCB and Flex PCB assembly, including encapsulants, protective coatings, conductives for chip, connector and wire bonding. Find the right adhesives for your entire medical device with help from our technical support team. They possess an incredible amount of hands-on experience with medical device applications.

Needle Bonding

Biocompatible adhesives from Panacol are suitable for bonding stainless steel needles or cannulas in glass or plastic syringes. We will support you in selecting the right adhesive for your specific substrates and syringe design.

more information on page 4

Catheters/Tubes/Diagnostics

For disposable medical products, Panacol offers a range of different adhesives that allow fast cycle times for high volume production. UV-curable Vitralit® adhesives are suitable for clear, visible light curable adhesives for UV-blocked materials.

more information on page 5

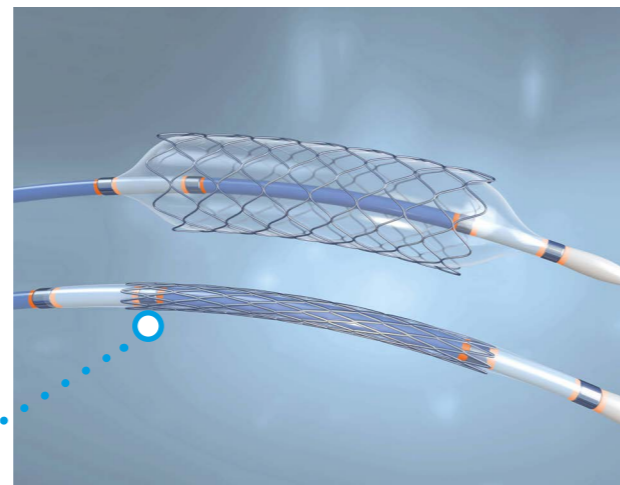
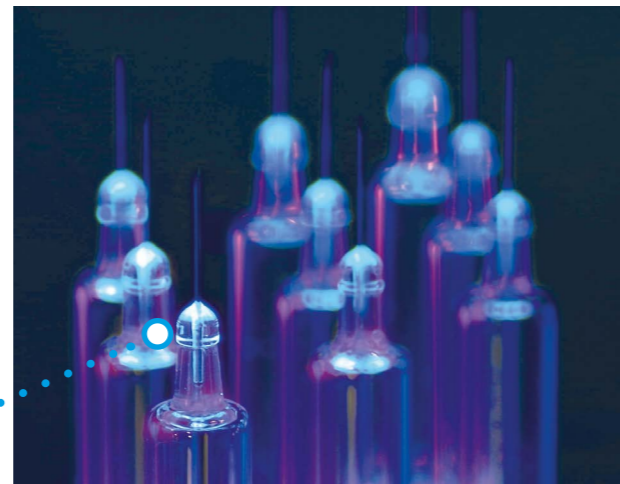

Electronic Packaging/Sensors

Adhesives from Panacol are used in sensor technology for the attachment and protection of components. Conductive adhesives can be used to ensure electrically conductive connections.

more information on page 5

Lens Bonding and Stacking for Endoscopes

UV adhesives with high optical transparency and low shrinkage are used to fix lenses in microscopes and endoscopes as well as in cameras and bonding of prisms.

more information on page 4

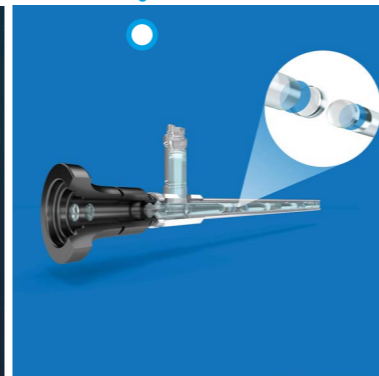

Tube and Connector Bonding

Acrylic-based UV plastic bonders from Panacol are suitable for bonding connecting elements such as infusion lines or tubes of catheters and other disposable products. They enable fast cycle times and create process-reliable production.

more information on page 4

Plastic Bonding

Bonding and sealing transparent polycarbonate or acrylic housings of dialysis filters, blood oxygenators, blood bags and valves of different sizes are quick and reliable with Vitralit® UV adhesives from Panacol.

more information on page 5

Wearables & Medical Devices

Panacol offers complete adhesive and curing solutions for structural housing bonding, needle bonding or bonding to PCBs in medical wearables or other medical electronic devices.

more information on page 6

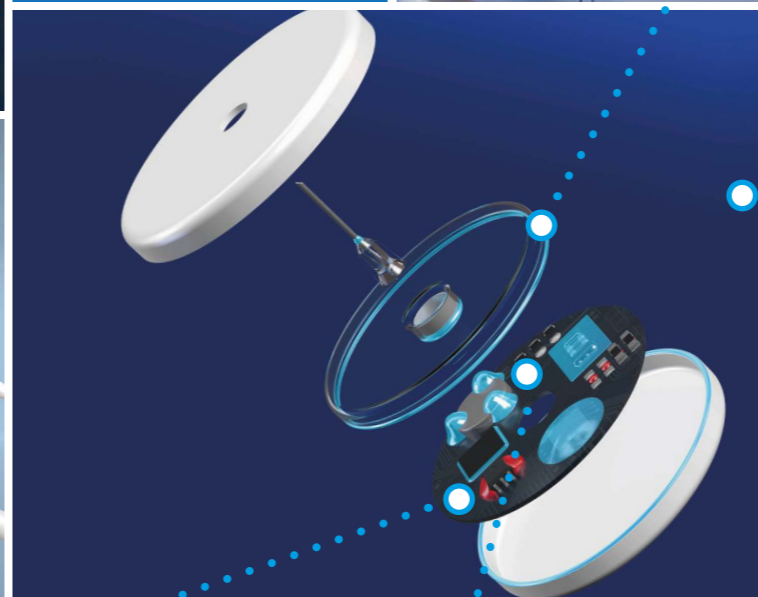

Conductive bonding

Panacol offers a wide range of Elecolit® brand thermally and/or electrically conductive adhesives. Elecolit® products are the contemporary answer to fast connectivity and thermal management for a wide range of applications.

more information on page 6

Medical Grade Adhesives Selection Guide

View the Panacol adhesives meeting the requirements for USP Class VI and/or ISO 10993 certification.

more information on page 7



Needle Bonding

UV adhesives for bonding stainless steel needles or cannulas in glass or plastic syringes are solvent-free and fluorescent for a better process control. Suitable for USP Class VI and/or ISO 10993 certification, they offer the ability to bond PC, PVC, PP or ABS to stainless steel and other metals. Fully cured, they withstand high needlepull-out forces even after several sterilization cycles. UV blocked plastics can still be bonded and cured with long-wave light.

Electronic Packaging/Sensors

Adhesives for sensors in medical technology are used for environmental protection, shielding, electrical connection and heat dissipation. These products meet ISO 10993 and/or USP Class IV standards, are solvent-free and withstand common sterilization processes. Vitralit® adhesives can be cured with UV or visible light for a precise, process-reliable and fast production. Shadowed areas of components can be safely cured with dual-cure adhesives.

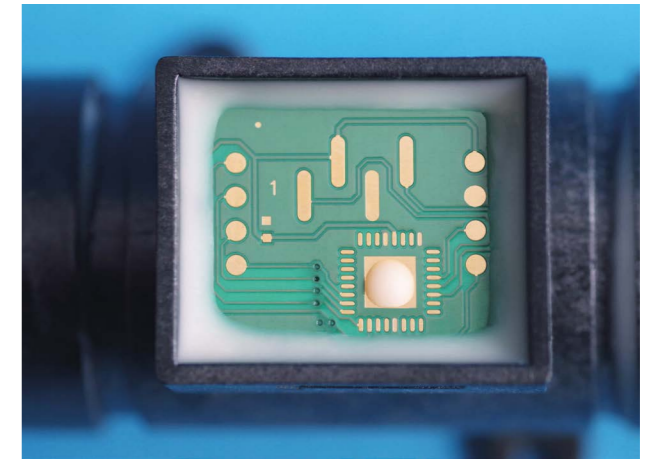

Tube and Connector Bonding

Vitralit® UV- and LED-UV-curing acrylate-based adhesives are suitable for connecting infusion lines or catheter tubing to stopcock valves, filters and adapters. They enable fast cycle times and process-reliable production. They are biocompatible and extremely resistant to chemicals and liquids. Depending on the application, they can be adjusted in viscosity to meet the required flexibility or strength for reliable bonding.



Plastic Bonding

For bonding and sealing transparent polycarbonate or acrylic housing halves, such as dialysis filters or blood oxygenators, Panacol offers Vitralit® brand light-curing one component adhesives. Multiple viscosity ranges are available to fill the smallest channels as well as larger bond line gaps. Components are joined within seconds using LED-UV or LED visible light curing systems. Structalit® 2-component adhesives are suitable for materials not transparent to UV and visible light. All adhesives are solvent-free and compatible with gamma, EtO and e-beam sterilization processes.

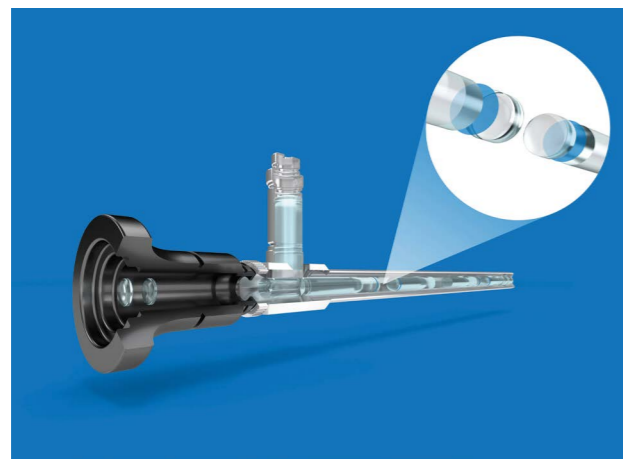

Lens Bonding and Stacking for Endoscopes

Dual curing Vitralit® adhesives are ideal for bonding lens stacks as well as attaching glass and rod lenses in endoscopes. High strength bonds are formed between glass and metal components that offer biocompatibility, good chemical resistance, and minimal shrinkage. Their high glass transition temperatures ensure operating stability and reliability. These adhesives are compatible with all common sterilization processes.

Catheters/Tubes/Diagnostics

Bonding of respiratory materials, catheters and other diagnostic products can be accomplished quickly and reliably using UV adhesives from Panacol. The adhesives meet the requirements of ISO 10993 and/or USP Class VI and bond not only the common plastics such as polycarbonate, PVC or ABS, but also substrates that are difficult to bond, including PEEK, PE and PP. They are solvent-free and highly resistant to moisture. Due to the products fluorescing under UV light, fast, efficient and cost-saving assembly processes can be realized.



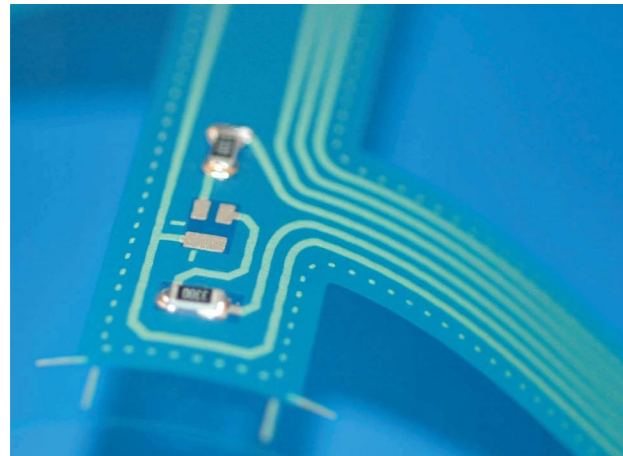

Conductive Bonding

Elecolit® electrically conductive adhesives are a suitable alternative to soldering processes. Their lower curing temperatures permit these conductive adhesives to be used for attaching temperature-sensitive chips and flexible conductors. In addition to forming electrical connections these mostly silver-filled adhesives offer heat dissipation, which reduces thermal stress on electronic components.

Wearables

Panacol's broad line of medical device adhesives enables manufacturers to select the exact adhesive properties required for their designs. For medical wearables, Panacol provides solutions for the complete device, including needle bonding, SMD packaging, protective coating, and housing assembly. Devices such as glucose monitors can be assembled quickly and reliably in high volume production processes. Our experienced technical team is ready to assist with recommendations for adhesives, curing systems, and dispensing options.

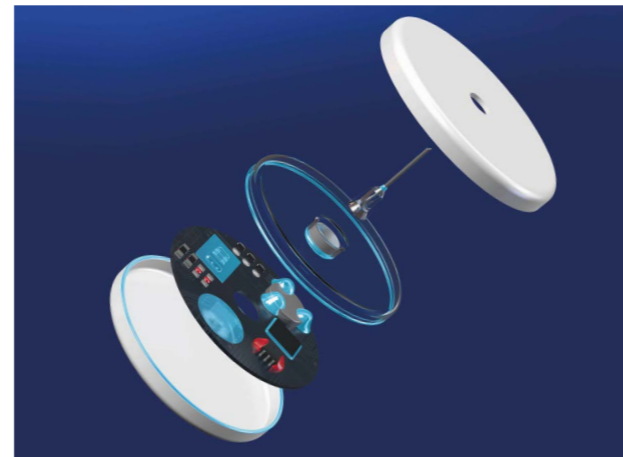

Adhesion properties of adhesives on different substrates														
Substrate	Adhesive	Vitrilit®												
		Structalite® 8801	1605	1655	1702	4731	E- 4731	UV 4050	5140	6108 /T	UV 7030	7041 /F/T	7044 VLV	7090 VHS
ABS	●	●	●	●	●	●	●	●	●	●	●	●	●	●
Aluminium	●		●		●	●	●	●	●	●				●
Stainl. Steel	●	●	●		●	●	●	●	●	●	●	●	●	●
Glass	●	●	●	●	●	●	●	●	●	●	●	●	●	●
PA6	●	●	●	●	●	●	●	●	●	●	●	●	●	●
PC	●	●	●	●	●	●	●	●	●	●	●	●	●	●
PEEK	●	●	●	●	●	●	●	●	●	●	●	●	●	●
PET-A	●	●	●	●	●	●	●	●	●	●	●	●	●	●
PMMA	●	●	●	●	●	●	●	●	●	●	●	●	●	●
PS	●	●	●	●	●	●	●	●	●	●	●	●	●	●
PU/PUR		●	●	●					●	●	●	●	●	●
PVC	●	●	●	●	●	●	●	●	●	●	●	●	●	●
SAN	●	●	●	●	●	●	●	●	●	●	●	●	●	●
PP/PE	Surface treatment always required													
Silicone	Surface treatment always required													

● very good ● application-related

Adhesive	Base	Viscosity [mPas]	Curing*	Compliance	Color	Characteristics
Vitrilit® 1605	1-part epoxy	200 - 400 LVT, Sp. 2/30 rpm	UV/thermal	ISO 10993-5	Transparent	Low shrinkage, low CTE, high glass transition temperature, excellent chemical resistance, dual cure
Vitrilit® 1655	1-part epoxy	150 - 300 LVT, Sp. 2/30 rpm	UV/thermal	USP Class VI ISO 10993-5	Transparent	Flexible, low viscosity, excellent adhesion to plastics and metals, dual cure, resistant to sterilization
Vitrilit® 1702	Acrylate	10 - 100 LVT, Sp. 2/60 rpm	UV/LED	USP Class VI	Transparent, slightly yellow	High adhesion to plastics, capillary flow, high E-modulus, high material strength, low oxygen inhibition, perfect solution for bonding hose connections, back-pressure valves or blood filters
Vitrilit® 1703	Acrylate	85,000 - 130,000 LVT, Sp. 4/3 rpm	UV/VIS	USP Class VI	Transparent, slightly yellow	Excellent adhesion to plastics, gap-filling, high E-modulus, specially formulated to bond hose connections, back-pressure valves and blood filters, shape retaining, shear thinning
Vitrilit® 4731	Acrylate	900 - 1,500 LVT, Sp. 2/30 rpm	UV/VIS	USP Class VI ISO 10993-5	Transparent	Flexible, excellent adhesion to glass and plastics, specially formulated to bond tubing connections or housings, dry surface
Vitrilit® E-4731	Acrylate	900 - 1,500 LVT, Sp. 2/30 rpm	UV/VIS	ISO 10993-5	Transparent	Flexible, excellent adhesion to glass and plastics, dry surface, CMR free
Vitrilit® 5140	Acrylate	250 - 500 LVT, Sp. 2/30 rpm	UV/VIS	USP Class VI	Transparent slightly yellow	Soft, flexible with dry surface cure, excellent resistance to thermal cycling, used in tube sets and breathing circuits or as coatings of electronic devices
Vitrilit® 6108	Acrylate	600 - 900 LVT, Sp. 3/30 rpm	UV/VIS/thermal	USP Class VI ISO 10993-5	Transparent	Dual cure, high resistance to moisture, very high adhesion to glass and metal. Ideal for bonding needles in glass syringes and endoscopes
Vitrilit® 6108 T		4,000 - 6,000 LVT, Sp. 5/30 rpm				
Vitrilit® 7041/F	Acrylate	50 - 90 LVT, Sp. 2/60 rpm	UV/VIS	USP Class VI	Transparent, slightly yellow	Capillary flow, very good adhesion to many plastics, suitable for needle bonding and joining connectors/tubes/housings or dialysis filters, fluorescent markers for in-line inspection
Vitrilit® 7041 T	Acrylate	1.500 - 2.300 Rheometer, 10s ⁻¹	UV/VIS	USP Class VI	Transparent, slightly yellow	High gap filling capacity, very good adhesion to plastics, suitable for bonding needles, tubings and connectors, reservoir assemblies and sealing filter cartridges, shear-thinning
Vitrilit® 7044 VLV	Acrylate	10 - 100 LVT, Sp. 2/60 rpm	UV/VIS	USP Class VI	Transparent	Excellent adhesion to rubber and elastomers, perfect solution for elastic bonding, resistant to sterilization
Vitrilit® 7090 VHS	Acrylate	40 - 100 LVT, Sp. 2/60 rpm	UV/VIS	USP Class VI	Transparent, slightly yellow	Capillary flow, very high adhesion to plastics, very fast curing at low intensities, high crosslinking. Well suited for sealing hollow fiber filters, needles and endoscopes
Vitrilit® 7311 (FO)		40 - 70				
Vitrilit® 7311 (FO) T	Acrylate	1,000 - 3,000	UV/VIS	USP Class VI	Transparent	Very good adhesion to many plastics, available in various viscosities, creates high strength bonds in the assembly of tube sets, connectors and housings, all adhesive variations are also available with orange fluorescence (FO)
Vitrilit® 7311 (FO) GEL		10,000 - 30,000 Rheometer 10s ⁻¹				
Vitrilit® 7562	Acrylate	500 - 900 LVT, Sp. 3/30 rpm	UV/VIS	USP Class VI ISO 10993-5	Transparent	Flexible, elastic, very high adhesion to glass and metal, specially formulated to bond glass apparatuses, moisture resistant
Vitrilit® 7989	Acrylate	3,000 - 5,000 LVT, Sp. 4/30 rpm	UV/LED	USP Class VI	Transparent, slightly yellow	Flexible adhesive with suitability for bonding connectors, reservoir covers, filter housings and enclosures requiring impact
Vitrilit® UV 4050	Acrylate	140 - 500 LVT, Sp. 2/30 rpm	UV/VIS	ISO 10993-5	Transparent, slightly yellow	Very good adhesion to many plastics, glass and metal, specially formulated for bonding needles, impact resistant
Vitrilit® UV 7030	Acrylate	15,000 - 25,000 Rheometer, 10s ⁻¹	UV/VIS	USP Class VI	Transparent	Flexible, high elongation at break, good shear strength, bonding plastics with low surface energy. Dry surface after UV-curing
Structalite® 5893	1-part epoxy	6,000 - 10,000 Rheometer, 10s ⁻¹	thermal	ISO 10993-5	Black	Fast curing at low temperatures, good shock resistance, specially formulated to bond medical disposables
Structalite® 701	2-part epoxy	3,000 - 5,000 LVT, Sp. 3/30 rpm	thermal	USP Class VI ISO 10993-5	Transparent, amber	Heat resistant up to 200°C, perfect for bonding surgical instruments/endoscopes/light guides, solvent free
Structalite® 8801	1-part epoxy	30,000 - 45,000 LVT, Sp. 4/6 rpm	thermal	ISO 10993-5	Beige	Suited for encapsulation of electronic devices and for potting of sensors, very good oil- and media resistance, low ion content, solvent free
Elecolit® 323	2part-epoxy	Paste-like	thermal	ISO 10993 -5/-12	Grey	Thermally and electrically conductive, solvent-free, suitable for semiconductors (Na+, K+, Cl- <10ppm), autoclavable (1000h)
Cyanolit® 203 TX	Cyano-acrylate	5,000 - 1,000 LVT, Sp. 3/6 rpm	RT	USP Class VI	Transparent	Gap-filling, high adhesion to plastics (PA, PC, ABS, PVC, EPDM), metal and elastomers, ideally suited for bonding of hose connections and porous substrates, resistant to moisture, shear thinning
Cyanolit® 241 F	Cyano-acrylate	30 - 50	RT	USP Class VI	Transparent	Capillary flow, very good wetting properties, ideally suited for bonding of plastics (PVC, PMMA), copper, aluminum and steel
Cyanolit® 732 F	Cyano-acrylate	230 - 350 LVT, Sp. 2/60 rpm	RT	USP Class VI	Transparent	Short curing time, wide range of applications, very good adhesion to plastics (PVC, PMMA, ABS, EPDM) & stainless steel, film-forming

*UV = 320 - 390 nm, VIS = 405 nm

Hönle UV technology for applications in medical device assembly

Dr. Hönle AG is an internationally recognized supplier of industrial LED-UV technology and traditional broad spectrum UV lamps as well as the head of the global Hönle Group, which Panacol is a member of. Hönle and Panacol place great emphasis on joint research and development, creating optimal curing solutions for Panacol's UV and visible light curing adhesives and coatings. Decades of mutual cooperation and experience have created product lines of high-tech curing equipment ideally suited for medical device assembly. The programmable software in each Hönle curing system provides full process control through continuous monitoring and feedback. Here a small selection:

LED Powerline

The LED Powerline is a high-power array with a very long lifetime. It is available with wavelengths of 365/385/395/405/460 nm and can therefore be precisely matched to the respective application. The length of the array can be increased in 40 mm steps from 80 mm to more than 1 meter. The compact and versatile LED Powerline is designed to be incorporated into production processes with minimal modification. It can be powered and operated from an existing PLC. The LED device is well suited for high-speed production, which includes needle and syringe bonding.



LED Spot 40 IC

The LED Spot 40 IC provides highly intensive UV or visible light curing energy for areas up to 40 x 40 mm. It is used where a point source is no longer sufficient, e.g., for the simultaneous

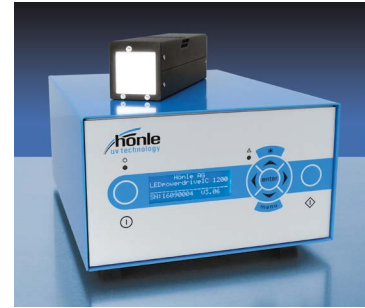

curing of several adhesive dots or for the curing of large diameters. The arrangement of the LEDs and an electronic power control ensure a homogeneous light distribution. An LED failure detection and extensive monitoring functions provide process reliability.

bluepoint LED eco

The bluepoint LED eco is perfect for applications that require high-intensity UV or visible light curing energy in diameters from 3 to 20 mm. Up to four LED heads can be operated by one controller, in programmed sequences or as totally independent workstations. Variable power settings, programmability of exposure cycles, and four wavelength options allow engineers to optimize their curing cycles and maximize their production output.



Further information and our standard product range are available at www.panacol.com

Contact us

Panacol-Elosol GmbH
Stierstädter Straße 4
61449 Steinbach
GERMANY
Phone: +49 6171 6202-0
info@panacol.de
www.panacol.com

Eleco Panacol – EFD
125, av Louis Roche
Z.A. des Basses Noëls
92238 Gennevilliers Cedex
FRANCE
Phone: +33 1 47 92 41 80
eleco@eleco-panacol.fr
www.eleco-panacol.fr

Panacol-USA, Inc.
142 Industrial Lane
Torrington CT 06790
USA
Phone: +1 860 738 7449
info@panacol-usa.com
www.panacol-usa.com

Panacol-Korea Co., Ltd.
#707, Kranz Techno
388 Dunchon-daero
Junwon-gu, Seongnam
Gyeonggi-do, 13403 KOREA
Phone: +82 31 749 1701
moon@panacol-korea.com
www.panacol-korea.com

Hoenle UV Technology Trading (Shanghai) Co., Ltd
Room 821, No. 800
Cimic Building Pudong
Shanghai 200120, CHINA
Phone: +86 21 64 73 02 00
info@hoenle.cn
www.panacol.cn